

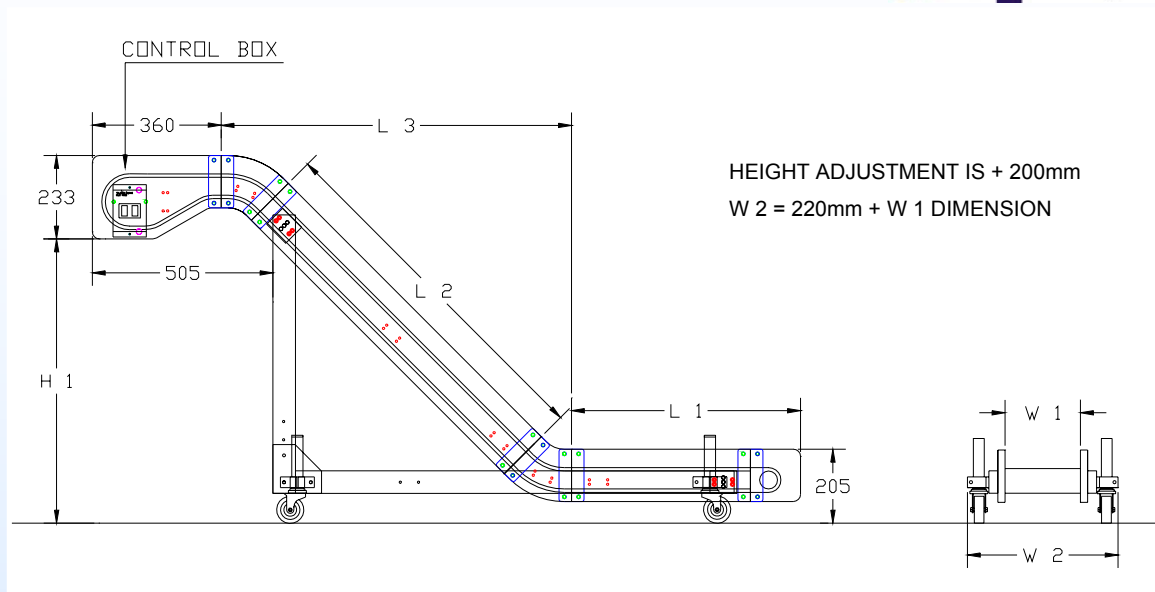

SW-SERIES CONVEYOR

- The new UPM belt conveyor has a precision machined belt track with minimum joints ensuring smooth product flow without hold up points or ingress of product into the track.
- The drive system incorporates a large diameter sprocket ensuring maximum drive efficiency with minimum gap around the radius.
- The inlet and outlet of the track are reduced in height to keep a slim line profile down to the feed end to ensure the conveyor can fit under the machine allowing maximum clearance for product movement.
- The conveyor construction allows simple modification to the length or shape in lengths of 0.5, 1, 1.5, 2, 2.5 and 3M sections.
- The conveyor side frames are HMWPE which is durable, tough and fully suited to operation in an industrial environment. Mounted in a purpose designed aluminium profile frame on heavy duty lockable castors.
- As with all UPM conveyor systems the link belt does not require tensioning or tracking.
- The polypropylene link belt is impervious to oil, water and able to operate with product temperature of 104 oC.

SW-SERIES CONVEYOR



		DIMENSION	DIMENSION	DIMENSION	DIMENSION	DIMENSION	DIMENSION	DIMENSION	DIMENSION	DIMENSION	DIMENSION	DIMENSION	DIMENSION
		L1 = 640	L1 = 1140	L1 = 1640	L1 = 2140	L1 = 640	L1 = 1140	L1 = 1640	L1 = 2140	L1 = 640	L1 = 1140	L1 = 1640	L1 = 2140
		L2 = 500	L2 = 500	L2 = 500	L2 = 500	L2 = 1000	L2 = 1000	L2 = 1000	L2 = 1000	L2 = 1500	L2 = 1500	L2 = 1500	L2 = 1500
		L3 = 625	L3 = 625	L3 = 625	L3 = 625	L3 = 1980	L3 = 1980	L3 = 1980	L3 = 1980	L3 = 1333	L3 = 1333	L3 = 1333	L3 = 1333
W1 =		H1 = 440	H1 = 440	H1 = 440	H1 = 440	H1 = 793	H1 = 793	H1 = 793	H1 = 793	H1 = 1147	H1 = 1147	H1 = 1147	H1 = 1147
211	MODEL	SW4520-1	SW4520-2	SW4520-3	SW4520-4	SW4520-5	SW4520-6	SW4520-7	SW4520-8	SW4520-9	SW4520-10	SW4520-11	SW4520-12
249	MODEL	SW4525-1	SW4525-2	SW4525-3	SW4525-4	SW4525-5	SW4525-6	SW4525-7	SW4525-8	SW4525-9	SW4525-10	SW4525-11	SW4525-12
288	MODEL	SW4530-1	SW4530-2	SW4530-3	SW4530-4	SW4530-5	SW4530-6	SW4530-7	SW4530-8	SW4530-9	SW4530-10	SW4530-11	SW4530-12
364	MODEL	SW4535-1	SW4535-2	SW4535-3	SW4535-4	SW4535-5	SW4535-6	SW4535-7	SW4535-8	SW4535-9	SW4535-10	SW4535-11	SW4535-12
403	MODEL	SW4540-1	SW4540-2	SW4540-3	SW4540-4	SW4540-5	SW4540-6	SW4540-7	SW4540-8	SW4540-9	SW4540-10	SW4540-11	SW4540-12
444	MODEL	SW4545-1	SW4545-2	SW4545-3	SW4545-4	SW4545-5	SW4545-6	SW4545-7	SW4545-8	SW4545-9	SW4545-10	SW4545-11	SW4545-12
499	MODEL	SW4550-1	SW4550-2	SW4550-3	SW4550-4	SW4550-5	SW4550-6	SW4550-7	SW4550-8	SW4550-9	SW4550-10	SW4550-11	SW4550-12

TECHNICAL DATA

- Conveyor sides grey HMWPE.
- Conveyor belts grey PP 104°C temperature.
- Internal direct drive system.
- Standard motor speed 4.5m / minute.
- Conveyor width <211mm 25w 80mm motor.
- Conveyor width >249mm 40w 90mm motor.
- 3ph 400v 50hz power supply.
- Control manual motor starter IP55.

OPTIONS AVAILABLE UPON REQUEST

- Fixed speed motors 1— 9m/min.
- Fixed speed motors 1PH 240V 50Hz
- Variable speed Inverter 1PH 240v.
- Machine interface controls.
- Belt colours Blue, White & Black PP.
- Belt flights 25mm, 50mm & 76mm.
- External High torque IP67 motors

UPM MACHINERY SALES LTD
LANGLEY BUSINESS PARK
BERKSHIRE
ENGLAND
SL3 6EP

Tel: 00 44 (0) 1753 548801
Fax: 00 44 (0) 1753 544115
Email: sales@upm.co.uk
Website: www.upm.co.uk