

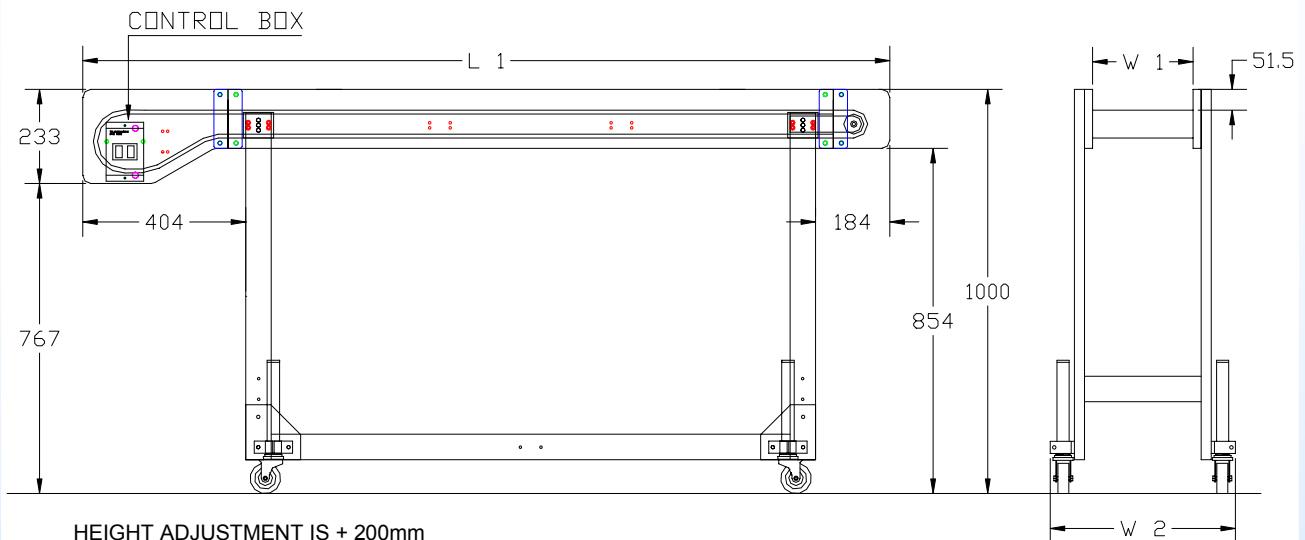

## H-SERIES CONVEYOR

- The new UPM belt conveyor has a precision machined belt track with minimum joints ensuring smooth product flow without hold up points or ingress of product into the track.
- The drive system incorporates a large diameter sprocket ensuring maximum drive efficiency with minimum gap around the radius.
- The inlet and outlet of the track are reduced in height to keep a slim line profile down to the feed end to ensure the conveyor can fit under the machine allowing maximum clearance for product movement.
- The conveyor construction allows simple modification to the length or shape in lengths of 0.5, 1, 1.5, 2, 2.5 and 3M sections.
- The conveyor side frames are HMWPE which is durable, tough and fully suited to operation in an industrial environment. Mounted in a purpose designed aluminium profile frame on heavy duty lockable castors.
- As with all UPM conveyor systems the link belt does not require tensioning or tracking.
- The polypropylene link belt is impervious to oil, water and able to operate with product temperature of 104 oC.

# H-SERIES CONVEYOR



HEIGHT ADJUSTMENT IS + 200mm

W 2 = 220mm + W 1 DIMENSION

	W1= 211	W1 = 249	W1 = 288	W1 = 364	W1 = 403	W1 = 441	W1 = 499
L1 = 1500	H20150	H25150	H30150	H35150	H40150	H45150	H50150
L1 = 2000	H20200	H25200	H30200	H35200	H40200	H45200	H50200
L1 = 2500	H20250	H25250	H30250	H35250	H40250	H45250	H50250
L1 = 3000	H20300	H25300	H30300	H35300	H40300	H45300	H50300
L1 = 3500	H20350	H25350	H30350	H35350	H40350	H45350	H50350
L1 = 4000	H20400	H25400	H30400	H35400	H40400	H45400	H50400
L1 = 4500	H20450	H25450	H30450	H35450	H40450	H45450	H50450
L1 = 5000	H20500	H25500	H30500	H35500	H40500	H45500	H50500
L1 = 5500	H20550	H25550	H30550	H35550	H40550	H45550	H50550
L1 = 6000	H20600	H25600	H30600	H35600	H40600	H45600	H50600

## TECHNICAL DATA

- Conveyor sides grey HMWPE.
- Conveyor belts grey PP 104°C temperature.
- Internal direct drive system.
- Standard motor speed 4.5m / minute.
- Conveyor width <211mm 25w 80mm motor.
- Conveyor width >249mm 40w 90mm motor.
- 3ph 400v 50hz power supply.
- Control manual motor starter IP55.

## OPTIONS AVAILABLE UPON REQUEST

- Fixed speed motors 1— 9m/min.
- Fixed speed motors 1PH 240V 50Hz
- Variable speed Inverter 1PH 240v.
- Machine interface controls.
- Belt colours Blue, White & Black PP.
- Belt flights 25mm, 50mm & 76mm.
- External high torque IP67 motors.

UPM MACHINERY SALES LTD  
 LANGLEY BUSINESS PARK  
 BERKSHIRE  
 ENGLAND  
 SL3 6EP

Tel: 00 44 (0) 1753 548801  
 Fax: 00 44 (0) 1753 544115  
 Email: sales@upm.co.uk  
 Website: www.upm.co.uk